



# OHIO TURNPIKE AND INFRASTRUCTURE COMMISSION

## CADD STANDARDS MANUAL



# CADD Standards

## Table of Contents

### **PART 1: Purpose**

#### Section 1.0 Purpose and scope of OTIC CADD standards

- 1.1 Why the Ohio Turnpike has data standards
- 1.2 Scope of the CADD standards
- 1.3 Who must use the standards?

#### Section 2.0 CADD Environment

- 2.1 Basic CADD Software
- 2.2 General Requirements

#### Section 3.0 Deliverables required by OTIC

- 3.1 CADD drawings
- 3.2 Documentation
- 3.3 Software and software licenses
- 3.4 Validation of delivered materials

#### Section 4.0 Communication about the CADD data standards

- 4.1 Suggestions for the standards

### **PART 2: Technical Requirements for CADD Data**

#### Section 5.0 Types of CADD files

- 5.1 Model Space
- 5.2 Paper Space

#### Section 6.0 CADD file names

- 6.1 Sheet file names
- 6.2 Default folder Structure
- 6.3 Submittals

#### Section 7.0 Layers

- 7.1 Layer Format

## Section 8.0 Drawing Set Up

- 8.1 Standard Sheets
- 8.2 OTIC Sheet Template
- 8.3 Drawing units
- 8.4 Accuracy
- 8.5 Scale
- 8.6 Origins and registration of CADD data files
- 8.7 Entities and graphic representation
- 8.8 Saved state of CADD model files
- 8.9 Sheet sizes, borders, and title blocks
- 8.10 Plotting
- 8.11 Sheet identification/numbering
- 8.12 Title blocks/borders

## Section 9.0 Symbology and Composition

- 9.1 Line types
- 9.2 Line type scale
- 9.3 Line weight and color
- 9.4 Text and Fonts
- 9.5 Annotation
- 9.6 Dimensions
- 9.7 Blocks
- 9.8 Hatching

## Section 10.0 Plan Sheet Format

- 10.1 Sheet Setup
- 10.2 Sheet Set Manager
- 10.3 Drawing Techniques
- 10.4 Drawing Techniques – Bridge Plans

## Appendix A: Layer Names

## Appendix B: OTIC CADD Drafting Conventions

## **PART 1: Purpose and Scope of OTIC CADD Standards**

The first part of this manual describes how to conform to these standards. The purpose and scope of the standards, receipt and delivery of data, and communication. The second part of the manual describes the Commission's technical requirements for CADD data.

### **Section 1.0 Purpose and scope of the CADD data standards**

#### **1.1 Why the Ohio Turnpike has data standards**

Computer-Aided Drafting and Design (CADD) is the chosen method of preparing plans for the Ohio Turnpike and Infrastructure Commission hereafter known as OTIC or the Chief Engineer of OTIC.

All drawing sets and files prepared by or for OTIC, shall be in accordance with the standards set forth in this manual. These requirements ensure that CADD files can be used by the entire project team (surveyors, planners, environmentalists, designers, reviewers, contractors, etc.) throughout all phases of project development. OTIC has adopted AutoCAD and AutoCAD Civil 3D as its standard drafting and design software packages, respectively.

Standards are necessary to ensure and maintain consistency throughout drawing files, as well as support files necessary for the preparation of OTIC projects. The purpose of this CADD Standard is to standardize drawing information and improve electronic data sharing between disciplines within OTIC and from consultants working for OTIC.

Please Note:

Actual software versions used by OTIC internally will upgrade from time to time, therefore please refer to the specific project contract or contact the project manager for actual version and submission requirements.

All new projects must use the latest version of the sheet template, available from the project manager. Please confirm the current sheet templates and supporting files prior to beginning any OTIC projects.

#### **1.2 Scope of the CAD data standards**

This data specification covers all construction documents prepared by or on behalf of OTIC. The deliverables described in this manual must be provided for each sheet that is issued for construction in a project and must include all supporting data files that are used to produce the finished sheets.

If additional electronic design drawings are provided, it is the responsibility of the consultant to ensure they are compatible with the software packages used by OTIC for those deliverables.

### 1.3 Who must use the standards?

Anyone who is going to prepare CADD plans for OTIC, including OTIC staff, contractors, and consultants, must read, and become familiar with this document before proceeding with any work. (The term "consultant" used in this manual refers to the person or organization who is preparing the CADD files, whether the person or organization is part of OTIC or not).

## Section 2.0 CADD Environment

### 2.1 Basic CADD Software

The designated CADD software for the Ohio Turnpike and Infrastructure Commission is Autodesk's AutoCAD. All CADD drawings are required to be delivered in AutoCAD's .dwg file format. Furthermore, all project submissions shall include the following file types. All project related Drawing Files shall be provided in both supported formats listed below.

- AutoCAD Drawing format (.dwg)                      “Preliminary Plans, Final Plans and Record Drawings”
- Adobe Portable Document Format (.pdf)            “Preliminary Plans, Final Plans and Record Drawings”

### 2.2 General Requirements

PDF files shall be created from within the AutoCAD environment and contain all the AutoCAD Layer information. It is a requirement that each project drawing/sheet created for a project be published/plotted to PDF. External Reference files are not permitted to be used.

## Section 3.0 Deliverables required by OTIC

### 3.1 CAD drawings

Consultants shall deliver to OTIC, a complete set of the project's CADD documents in electronic form and must be delivered as follows:

- In the current AutoCAD version.

#### *Neutral File Format*

CADD graphic files copied to neutral file exchange formats are not acceptable.

#### *AutoCAD current version file format*

All files must be delivered in native .DWG file format in a version that can be used by the currently supported version of AutoCAD. DXF format files are not acceptable.

### *Conformance to CADD data standards*

The CADD data delivered to OTIC by consultants must comply with the Commission CADD Standards that are in effect during the current project.

The current project's CADD drawings may contain information that has been extracted from existing OTIC AutoCAD drawings, which may not conform to the current CADD standards. The consultant must make sure that all CADD data delivered with a project conforms to the current CADD data standard, even if the source drawings did not conform.

The consultant will be required to update any non-conforming CADD drawings that are used to produce the current project's drawings.

### **3.2 Documentation**

The delivered CADD drawing files must be accompanied by the documentation described below if there were OTIC approved deviations from any CADD Standards. This information must cover all CADD files delivered to the OTIC.

- There are no exceptions to the standard layer structure.
- There shall be no deviations from the CADD Standards. Any CADD Standards deviation will result in the files being rejected.
- No third-party CADD software products shall be used in creating drawings. This is necessary so as not to affect the ability of OTIC to review or edit the drawings.

### **3.3 Software and software licenses**

Delivered CADD files requiring additional software licenses or software installation are not permitted and the files will be rejected.

### **3.4 Validation of delivered materials**

OTIC will validate the CADD data and other materials submitted by consultants. OTIC will reject submittals that do not conform to OTIC's CADD data standards.

The consultant is responsible for revising the materials to make them conform to the standards.

## **Section 4.0 Communication about the CAD Standards**

Consultants need to familiarize themselves with OTIC's CADD Standards before beginning work. Any concerns regarding OTIC's CADD Standards and their impact on a project must be discussed with the Project Manager prior to beginning work.

## **4.1 Suggestions for the standards**

The content of the manual is intended to be neither static nor all-inclusive and thus will be updated and enhanced as appropriate. Suggestions for improvements are encouraged so that subsequent updates reflect the needs of OTIC. Submit suggestions, as well as any pertinent new information which would enhance these standards, to the OTIC Project Manager.

## **PART 2: Technical Requirements for CADD Data**

### **Section 5.0 Types of CADD files**

The Turnpike's CADD files will include two distinct working environments, model space and paper space.

Model space by default, is a limitless 3D working drawing area and contains most of the project's data, such as quantities, dimensions, and text.

#### **5.1 Model space**

Model space contains the graphics, which describes a subset of a structure's or roadway's geometry and their physical components: survey points, site survey, contours, bridge and bridge components, walls, bearings, columns, beams, cross sections, ducts, etc. This information can be thought of as a "model" of the structures involved in a project.

A model must be created at real size: 1=1. Most structures and roadways are described by a series of two-dimensional models: plans, elevations, sections, and details.

#### **5.2 Paper Space**

One of the two primary spaces in which objects reside. It is within paper space where a layout of specific views of the project model, border and title block, and general notes are placed to print a clean and consistent document.

All secondary drawing elements shall be placed in Paper Space. Title block, sheet notes, titles, and legends shall be considered secondary drawing elements.

Paper space is used to assemble model views, title blocks, and other information for plotting. A Paper Space sheet contains one or more scaled views of one or more models arranged within a border and title block.

Dimensions, symbols, and keynotes would typically be placed in model files. Borders, title blocks and general notes would typically be placed in sheet files. The same layer names would be used in both cases.

## Section 6.0 CADD file names

CADD file names are based on projects job number identification using mile post designations for further clarity when needed. CADD files must be named using a (six-character job number followed by a short description title), where each file name has two characters, followed by a hyphen, two characters, a hyphen, two characters, a space, then a description.

The file names must follow the naming rules described in this section of the manual. Rules are described for sheet files.

The three-character extension for CADD drawing files must be DWG. The following naming convention is required for sheet file name.

### 6.1 Sheet file names

Sheet file names must be constructed in the format in Table 1.

Example: 432101-TITLESHEET.dwg

OTIC Project Number Acronym				
Project Type	Project year Build	Project Type Sub-Number Sequence	Description	Extension
<b>43</b>	<b>21</b>	<b>01</b>	<b>TITLE SHEET</b>	<b>.dwg</b>

Table 1: Sheet file name example

#### *OTIC Project Number Acronym*

The first two characters reflect the specific acronym given to every OTIC project. A hyphen is required between the last acronym number and sheet description.



*Project type*

The characters show the number that must be used for the first characters of the project type shown in Table 2.

<b>Code</b>	<b>Discipline</b>
24	Guard Rail Additions & Replacements
26	Roadway Lighting
39	Pavement Replacement
40	Repainting Bridges & Towers
43	Bridge Repairs & Resurfacing
53	Service Plazas
55	New Interchanges
56	Maintenance Buildings
58	Toll Plazas
59	Resurfacing
70	Slope Repair

Table 2: CADD file discipline codes example

## 6.2 Default Folder Structure

Electronic file submissions shall be provided in the following Default Folder Structure. Each discipline will have its own additional requirements; see the respective discipline section of this document for further details.

The Project Folder shall begin with the project file number assigned (available through the OTIC Project Manager).

### Folder Structure

00 Project Reference – For OTIC use.

01 Commission Correspondence – For OTIC use.

02 Design Correspondence – For OTIC use.

03 Design Emails – Design specific emails.

04 Design Phase – All working CAD files. sub-folders – Design calculations, inspection photos, inspection sheets, sheet sets, special provisions, and standard drawings, etc.

05 Bidding Phase – Working PDF Sheet Set submittals, bid tabs.

06 Final Bidding Documents – Final PDF Sheet Set submittals.

07 Invoicing and Change Orders – Consultant and contractor invoices.

08 General Correspondence – When used.

09 Design RFP’s – When used.

10 Project Progress Items – Meetings, monthly progress reports.

20 Agencies – Involved in the Project.

30 Design Items – For OTIC use.

40 Drawings General – Misc. drawings related to project.

50 Contracts – For OTIC use.

60 Safety – For OTIC use.

70 Construction Schedule - For OTIC use.

80 Construction Items – When applicable.

90 Quality Assurance and Inspection – For OTIC use.



















 00 Project Reference
 01 Commission Correspondence
 02 Design Correspondence
 03 Design Emails
 04 Design Phase
 05 Bidding Phase
 06 Final Bidding Documents
 07 Invoicing and Change Orders
 08 General Correspondence
 09 Design RFP's
 10 Project Progress Items
 20 Agencies
 30 Design Items
 40 Drawings General
 50 Contracts
 60 Safety
 80 Construction Items
 90 Quality Assurance and Inspection

Table 3: File Structure Example

Table 3: File structure example

### *Submission Workflow*

When a submission level is reached, ALL folders shall be copied, intact, to the appropriate submission level folder, i.e., Preliminary Documents and Final Bidding Documents. No external references are permitted.

Do not use the AutoCAD E-Transmit function when submitting project data.

This submission folder will then become the appropriate submission package to OTIC. No external reference, such as DWG, TIFF, BMP, etc., outside of the folder structure is permitted. It is the intent of this procedure to maintain the SUBMISSIONS as a “snapshot” or archive of submitted project files at their respective submission level. Once the submission has been reached, work will continue on the project, using the files located within the working folders.

### **Section 6.3 Submittals**

All submittals are to be provided in electronic format only – plan documents, reports, bid forms and engineer’s estimates in pdf format. In addition, all drawing files are to be submitted in AutoCAD dwg format and Bid Forms/Engineer’s Estimates are to be submitted in Microsoft Excel format.

#### Requirements for Preliminary Plan Submittals.

Include the following for (Bridge Submittals):

1. Typical Section of existing and Proposed Approach Roadway including cross slope and superelevation.
2. Typical Section of Existing and Proposed Bridge including cross slope.
3. Horizontal and vertical geometry through project limits.
4. Tie in elevations at approach roadway.
5. Benchmarks.
6. Minimum, vertical clearance.
7. Title sheet with location map, sheet index, standard drawings, and supplemental specifications.
8. Construction Phasing Details (if applicable).
9. MOT plans.
10. MOT notes.
11. Detour plans.
12. General Plan and Profile sheet nearly complete and checked.
13. Substructure Repair Details (patching and crack repair).
14. Abutment Slab Details (geometry only).
15. Deck Slab Plans (geometry only).

16. Transverse Slab Details (geometry only).

**Section 7.0 Layers**

The OTIC has adopted in part a set of approved CADD Standard Layers. Although it may have been common practice to use hundreds of available layers to contain plan data, the Ohio Turnpike recognizes the benefits of better organized data and plan efficiency using a smaller set of layers. Consultants are expected to use only the identified OTIC layers. No revisions and/or additions to layers will be excepted without written approval of the OTIC Project Manager.

Layers are included in OTIC’s AutoCAD Sheet Template.

Consultants who do not follow these layering standards risk having submittals rejected by the OTIC.

**7.1 Layer Format**

The drawing template has been provided with standardized layers designed to accommodate information required in any drawing. No additional layers are permitted.

*Layer name with major group, minor group, and identifier field*

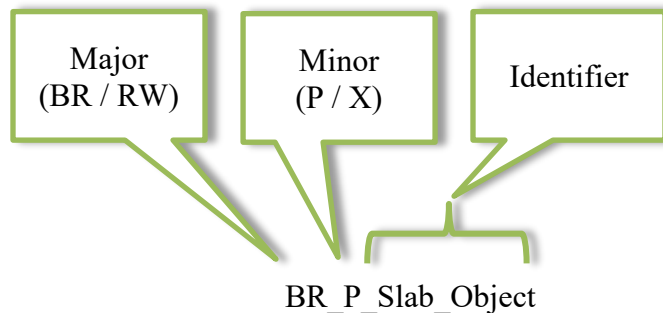

Major Codes	Minor Codes	Identifier
BR - Bridge	P – Proposed Feature	Feature Description
RW - Roadway	X – Existing Feature	Feature Description
SH – Sheet	- - - -	Feature Description

Table 4: Layer name discipline

**Section 8.0 Drawing Set Up**

This section describes how to organize and set up CADD drawings for OTIC. It has been prepared using layering guidelines and uniform drawing standards.

There shall be no deviation from these drawing set up standards.

## 8.1 Standard Sheets

Half-size sheets measuring 11 × 17 inches plottable to 22 × 34 inches.

Half size sheets will be used for engineering projects as identified by OTIC.

Create each sheet as an individual **.dwg** file. Do not use multiple Paper Space layouts to create more than one sheet in one drawing file. An exception to multiple Paper Space layouts would be for small projects with a minimum number of drawings and data or by the approval of the project engineer. The Layout tab shall indicate the drawing file name.

Plans must include, at a minimum, the standard items depicted in the Commission's sample plan sheets.

The Ohio Turnpike implemented The Ohio Department of Transportation's Location & Design Manual – Volume 3 (ODOT L&D) drawing procedures.

The guidelines contained in Location and Design Manual, Volume 3 are considered a primary source of reference by personnel involved in the preparation of bridge and roadway plans for the Ohio Turnpike and Infrastructure Commission.

Additional OTIC guidelines also considered a primary source, are included in the index of this manual.

## 8.2 OTIC Sheet Template

Utilize OTIC Provided AutoCAD template: **acad-OTIC.dwt** for all standard drawing sheets. Multiple paper space sheet tabs are included in the template for multiple drawing types:

- Title Sheet
- Bridge Plan Sheet
- Roadway Plan Sheet
- Roadway P&P Sheet

## 8.3 Drawing units

CADD files should use the architectural (feet and inches) units. Roadway drawings may use the engineering (feet and tenths) units.

## 8.4 Accuracy

All CADD drawings shall be drafted using precision input employing the most accurate source material available. For all drawing entities, zero tolerance is required, all lines meet at intersections, straight lines are straight, blocks are inserted properly without overlap, etc.

Consultants are responsible for the accuracy of all CADD drawings delivered to OTIC, regardless of the accuracy of CADD drawings of previous projects furnished by the OTIC as a convenience to the consultant.

## 8.5 Scale

Objects shall be created at full size--a 100-foot wall will be drawn to 100 feet and a 36-inch column will be drawn to 36 inches. The following types of CAD drawings may be drawn to any scale: schedules, schematic and single line diagrams but must be uniform in size of similar drawings in a plan set.

Details are to be drawn to scale, but scales are not to be indicated on bridge plan sheet. Scales are to be generally accepted scales (1" = 20', 1" = 40', 1/4" = 1'-0", 3/4" = 1'-0", etc. – not 1" = 27.5' or 1/6" = 1'-0", etc.).

Scale of details can be distorted for clarity's sake, i.e., for beam elevation details, the height of the beam can be drawn to an exaggerated scale with respect to the length for clarity of details. Width of the deck slab can be exaggerated with respect to the length for clarity. When placing reinforcing steel in a detail (slab, elevation, section, etc.), the line depicting the bar does not have to be drawn exactly to scale depicting the 2" clearance dimension, the distance between the object line and the reinforcing bar line is to be distorted so the lines don't "bleed" together.

## 8.6 Origins and registration of CAD data files

The origins of CADD model files must be defined at coordinates 0, 0, 0. This is typically the lower left corner of the design.

The origin point must remain consistent between all model files in a project. This is critical for correct registration of different model files when referenced together, aligning the various views of the project. Registration of electronic data must be maintained so the information will be usable in future applications.

The origin of each CADD sheet file should be at the lower left-hand corner of the sheet border and set to coordinates 0, 0, 0.

### *Special considerations for site plans*

Roadway model files may use true geographic coordinates for their origins.

## **8.7 Entities and graphic representation**

### *Curved Entities*

Circles, arcs, and ellipses shall be created as individual entities, not of line segments.

### *Drawing Limits*

Drawing and extents must be checked to ensure there are no objects outside the drawing limits. Objects outside the drawing limits will slow the regeneration and manipulation of the drawing. All drawings shall be submitted with the drawing display zoomed to the drawing extents.

### *Entity Properties*

Entity properties such as color and linetype shall be BYLAYER. For purposes of clarity, some symbol and block properties may not be set BYLAYER, but this should be avoided whenever possible.

## **8.8 Saved state of CAD model files**

CAD files should be delivered in the state described below.

- Blocks should not be exploded.
- Drawings should be purged.
- Drawings should be zoomed to extents.
- Drawings should be left in paperspace if using paperspace.
- Drawings should be free of external references (Xref's).
- Do not use OLE items on drawings (such as linked spreadsheets, etc.) All tables are to be AutoCAD entities.

## **8.9 Sheet sizes, borders, and title blocks**

Standard drawing sizes shall conform to the American National Standards Institute (ANSI) adopted ANSI/ASME Y14.1. ANSI defines paper sizes based upon the de facto standard 'US Letter' size (8.5" x 11") which is called 'ANSI A'. Double ANSI A sheet size parallel to the shortest side produces an ANSI B (11" x 17") 'Ledger/Tabloid' sheet size. This series is also referred as (half size) sheet to the standard full size ANSI D (22" x 34") full sheet size.

OTIC plan sheets shall be produced in paper space to a half size (11" x 17") sheet.

## **8.10 Plotting**

Each sheet drawing file generally represents a single plotted drawing. The sheet origin point is the lower left-hand corner of the sheet. The sheet border may be an xref file inserted at 0,0 and bond to the sheet. No drawing entities should reside outside of the sheet's border. When saving a sheet file, make only the layers needed for correct plotting of the sheet visible. Plotting shall be set at a scale of 1"=1".

## **8.11 Sheet identification/numbering**

Sheet sequence identifier numbers start at 1 and continue in sequence numerically. The Construction Specifications Institute (CSI) UDS guidelines shall be used unless an exception is approved by the Chief Engineer.

It is recommended sheet number be managed through the Sheet Set Manager (see Sheet Set Manager for further reference).



### 8.12 Title blocks/borders

Title blocks and borders are based on CSI Uniform Drawing System (UDS) guidelines and industry standards. A title block layout and schematic sheet setup follows in table 5.

Refer to the provided OTIC sample sheets for additional guidance.

#### Title Block Area

Identifies designer or preparer of sheet. Include: Name and Address Telephone/Fax Number or Email (Optional) Block may also include preparer's logo	DESIGNER INFORMATION BLOCK
Shows the issue and revision dates. Include mark, date, and description columns.	REVISION BLOCK
Identifies the makers of the sheet contents. Includes: The initials of who Designed, Checked, Drawn and In Charge Engineer.	MANAGEMENT BLOCK
Identifies the project. Includes: Sheet Title, project location name, mile post (MP) location and county the project is located in.	PROJECT INFORMATION BLOCK
Identifies the project. Includes: Project number and plan approval date.	PROJECT IDENTIFICATION BLOCK
Subset sheet numbers. Identified as a set of plan sheets in a series such as a set of bridge plans inside a set of project plan sheets.	SHEET SUBSET NUMBERING BLOCK
Sheet number Sheet sequence number	SHEET NUMBERING BLOCK

Table 5: Title Block Areas

*Schematic Sheet Layout*

OVERALL SHEET LAYOUT SCHEMATIC  
 BASED ON CSI UNIFORM/ DRAWING SYSTEM

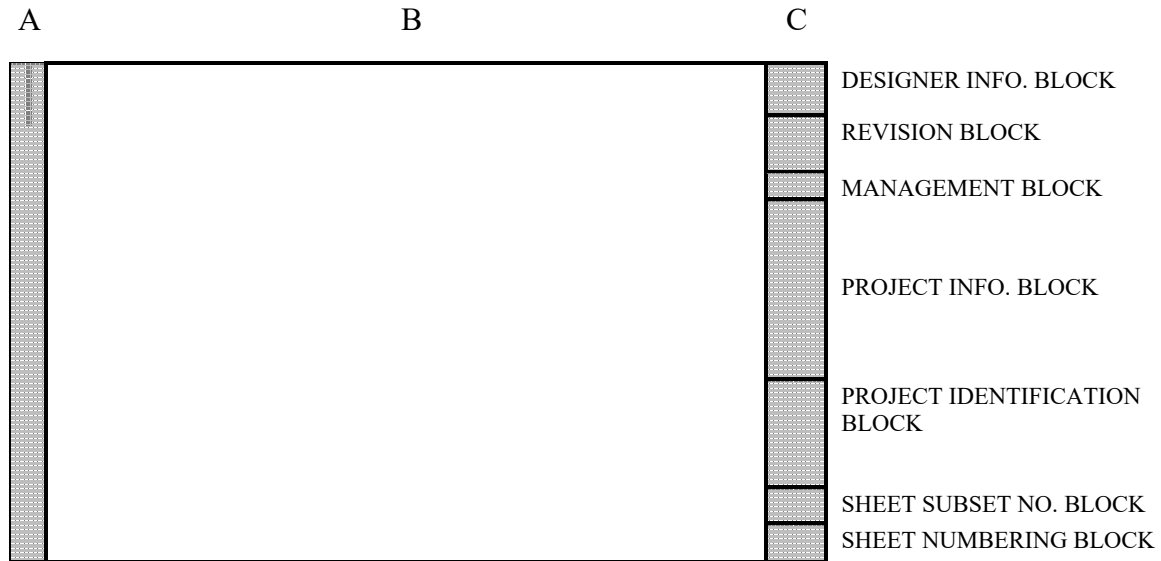

- A PRODUCTION DATA/BINDER AREA: Checking Print documentation and RTEXT sheet naming identifier
- B DRAWING AREA
- C TITLE BLOCK AREA

## Section 9.0 Symbology and Composition

### 9.1 Line types

All line types shall be based on the default AutoCAD line types from the file ACAD.LIN. The Ohio Turnpike is focused on simplifying plan sheet linetype usage and requires the use of only 3 linetypes for both bridge and roadway plan sheets.

Bridge Linetypes:

- a. CONTINUOUS for all lines except as specifically noted herein.
- b. CENTER2 for all centerlines and baselines.
- c. HIDDEN2 for all hidden objects regardless of existing or proposed objects.
- d. **DO NOT USE phantom or dashed lines for existing object lines.**

Roadway Linetypes:

- a. CONTINUOUS for all lines except as specifically noted herein.
- b. CENTER2 for all centerlines and baselines.
- c. HIDDEN2 for all hidden objects regardless of existing or proposed objects.

Polylines with increased width may be used only to depict non-building drawing elements such as cut-lines.

Plans may be rejected if these Linetype Standards are not followed.

### 9.2 Line type scale

Plans shall be developed in AutoCAD with details in model space, “plan sheet” is produced in paper space to half size sheet - 11”x17” pdf using the plotter configuration file dwgtopdf.pc3 driver. Layout is to be set so LTSCALE of 0.5 plots properly.

### 9.3 Line weight and color

Line weight and color affect the usability of CADD data in different ways. Line weight typically is most useful when working with plotted CADD drawings. Plots, or reproductions of plots, are usually monochrome and the thickness of lines is an important means of communicating information about the facility and the design.

Color is most useful when working with CADD data on a computer screen. Colors allow users to readily identify systems and types of information. On a computer screen, line weight often gets in the way of effective communication.

## 9.4 Text and Fonts

All text on OTIC CAD drawings shall utilize only the supplied OTIC True Type Font. Utilize AutoCAD symbols so as not to overlap individual letters to create  $\text{C}$ ,  $\text{E}$ ,  $\text{B}$  etc. CADD files submitted shall be plottable without modification and with no additional software required.

Text size must be legible and in all capital letters, with text size for printed 11" x 17" plan sheet to = 1/16". Detail titles are to be generated using the same text style as for all other text except size. Detail titles shall be double the text height at 1/8".

### *Text placement guidelines*

Use annotative text, dimensions, hatching, etc. Lettering is to be oriented such that it can be read either from the bottom or right side of the plan sheet (reference ODOT L&D Volume 3, Section 1202.4.1)

Text usually should not touch other graphic objects and must be placed with enough space around it to be legible when the drawing is plotted and reproduced.

Text may be placed at an angle. It must be readable from the bottom or right edges of the plotted sheet. Generally, text should be placed at an angle of 0° or 90°. Text may be placed along (above or below) another element at an angle other than 0° or 90°.

### *Units*

English (Architectural in AutoCAD) units shall be the standard system of measurement. The base unit shall be inches.

## 9.5 Annotation

Annotative objects and styles are used to control the size and scale at which annotation objects are displayed in model space or a layout. Annotative objects are defined by specifying a paper height or scale, and then the annotation scales at which they should be displayed.

Each viewport on a layout is assigned an annotation scale, which is often the same as its viewport scale value. The annotation scale of a viewport or model space, controls when the annotation object is displayed and at which size.

Annotation can be placed in either model space or paper space. Annotations related to model data, such as dimensions, notes, and callouts must be included in the model space where they are easier to coordinate and revise.

Other annotations, such as drawing titles, legends, and sheet-specific notes, are more convenient to work in sheets and thus should be placed in paper space.

## 9.6 Dimensions

Dimensions should be associative, which mean that they adjust to changes in the geometric objects that they measure.

Dimension associativity defines the relationship between geometric objects and the dimensions that give their distance and angles. Several types of relationships are possible between geometric objects and dimensions. Leader and multileader objects can also be associative.

Associative dimensions automatically adjust their locations, orientations, and measurement values when the geometric objects associated with them are modified. Dimensions in a layout may be associated to objects in model space. These are created when the DIMASSOC system variable is set to 2.

Dimensions are to be placed outside areas whenever possible per ODOT L&D 1202.4.7

Dimension text is to be placed as per ODOT L&D 1202.4.11, 1202.4.12, 1202.4.13, 1202.4.14, 1202.4.15, 1202.4.16, 1202.4.17 and 1202.4.18

Consultants should ensure that all dimensions are in the annotative dimension style laid out in the sheet template file **acad-OTIC.dwt** for all dimensions, so the dimension parameters can be readily modified as needed.

## 9.7 Blocks

Any graphic entity that occurs repeatedly in drawings should be made into a block. Insertion points for blocks shall be consistent with its placement in the drawing. Use a logical insertion point (center of circle, bottom left corner of object, etc.). Keep names simple and descriptive. AutoCAD block names must be unique within each project.

Nested blocks contain more than one block definition. Nested blocks are permitted but should be avoided whenever possible.

## 9.8 Hatching

Do not use polylines with increased width as a replacement for hatching. Use pattern hatching sparingly.

## Section 10.0 Plan Sheet Format

### 10.1 Sheet Setup

Utilize OTIC provided AutoCAD template: acad-OTIC.dwt.

While Sample Plans are provided for your reference for development of plan sheets, they are to be used as a general guideline for how details are expected to be presented and NOT to be utilized as standards for engineering principals, design guidelines, reinforcing bar sizes, bar spacing, bolt and plate sizes, etc.

Definitions: (See 10.1 Line types) for appropriate line type use.

- a. Existing Object – which already exists.
- b. Proposed Object – an object which will be placed with the new construction.

Units – use architectural and 1/16” precision.

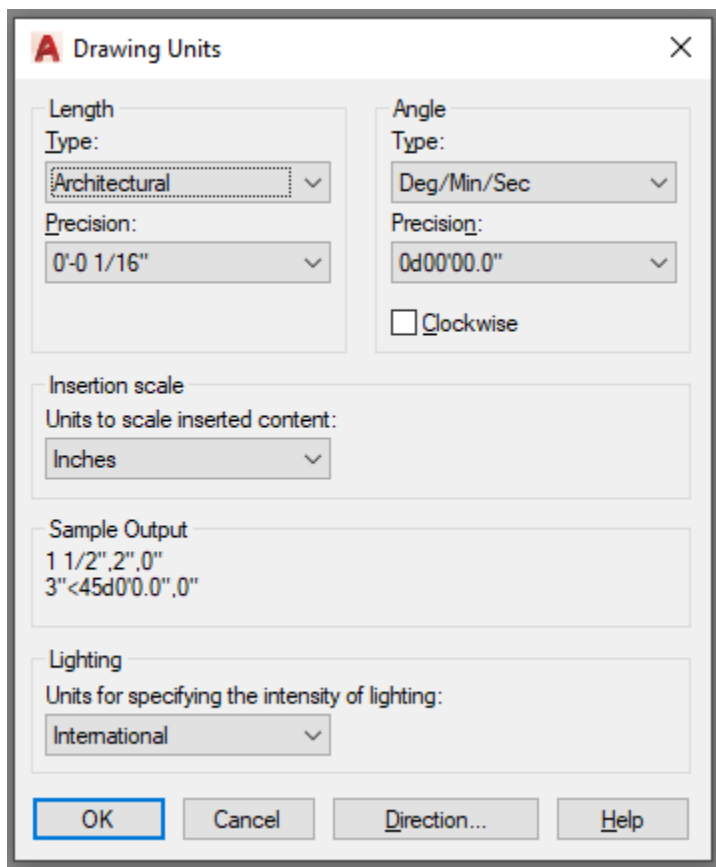

## 10.2 Sheet Set Manager

Sheet Set Manager (SSM) is a powerful tool that will ensure consistency with every sheet in every plan set by allowing the End-User to organize, display, edit, and manage drawings all in one location.

OTIC requires plan sheet sets be organized for maximum efficiency easy access and publishing. The practice of utilizing Sheet Set Manager (SSM) to organize project plan sheets within AutoCAD is required. The cross-referencing fields help manage plan sheet titles, project numbers, mile posts (MP), sheet numbering, county names etc. A Sheet Set Template is included with the sample plan sheets.

The .dst Sheet Set file name shall be the project number followed by an underscore and the project name (words separated by underscores): Project Number\_Sheet Set.dst For example: (43-20-10\_Sheet Set.dst). The .dst file must be included with the final electronic deliverables.

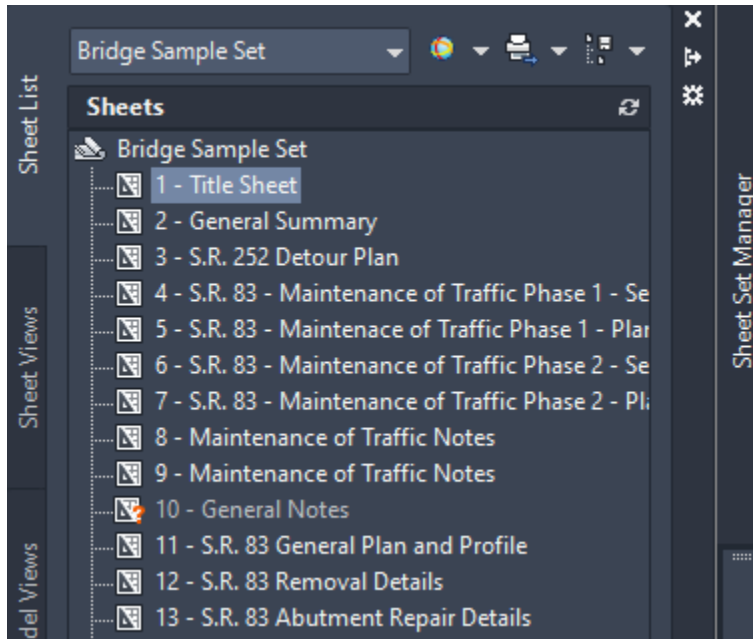

Maintaining the sheet set included in the example sheets provides the organizational structure and default settings for a new set of sheet plans. Specify that folders are created corresponding to the subset storage paths of the sheet set. After you create an empty sheet set with this option, you can Import layouts or create sheets individually.

When creating a sheet set from existing drawings, specify one or more folders that contain drawing files, and you can specify that the subset organization for the sheet set duplicates the folder structure of the drawing files. The layouts from these drawings can be imported into the sheet set automatically.

### 10.3 Drawing Techniques

Utilize ODOT Design manuals and drawing techniques described in the ODOT L&D (Location and Design) including additional OTIC drawing practices.

1. Placement of Leaders from notes is to follow ODOT L&D 1202.4.2
2. Placement of Leaders to or from a circular object is to follow ODOT L&D 1202.4.3
3. Leaders are to terminate as per ODOT L&D 1202.4.4
4. Placement of balloons are to be per ODOT L&D 1202.4.5
5. The use of “Typical” is to be per ODOT L&D 1202.4.19
6. No lines shall be displayed thru text.
7. No crossing of dimension lines or extension lines
8. Abbreviations are not to be used in any sheet titles or detail titles nor in any plan notes and are to be used where only absolutely necessary due to size constraints in details.
9. Utilize pen table OTIC-Half.
10. Utilize proper names of entities:
  - a. Ohio Turnpike *not Turnpike*
  - b. Ohio Turnpike *not I-80, I-90, or I-76*
  - c. Ohio Turnpike & Infrastructure Commission *not Ohio Turnpike Commission*
  - d. OTIC *not OTC*
  - e. Parapet (If located within the bridge limits) *not barrier (roadway item)*
11. Stationing is to be oriented on the General Plan/Site Plan to increase on the sheet from left to right, regardless of what the orientation was on any previous plans.
12. Reference ODOT BDM Section 102 for proper orientation/callouts of the bridge (rear/forward and right/left).
13. Quantities as presented in plan tables, subsummaries and summaries shall be shown to an accuracy to match that of the pay item, i.e., to the nearest whole cubic yard, square yard, pound, lineal foot, etc. The only exception to this is on quantities based upon a MILE unit of measure, which are to be shown to the nearest 1/100th of a mile. Actual payment for all pay items will be made as per the requirements of the L&D Manual and CMS 109.01, to 1/10th decimal place.
14. Special Provisions are designated as such **SP 516A**, not **SP516A**, **SP516 A** or **SP 516 A**.
15. Prior to plan sheets being submitted to the OTIC for review, all plan sheets are to be checked for conformance to the OTIC standards by utilizing the OTIC.dws file.
16. Quantity Units shall be presented in plan tables, subsummaries and summaries as shown in the appropriate CMS or OTIC Special Provisions. (e.g., FOOT not LIN. FT.)



17. Place items in the General Summary tables, Estimated Quantity tables and estimated quantity worksheets in numerical order. Items are grouped in the General Summary table by discipline – Roadway, Maintenance of Traffic, Traffic Control, Drainage, Structures, etc. General Items are listed in the first group and structures are listed in the last group in the tables. The order of the items in the estimated quantity worksheet is to be identical to that in the General Summary table.

#### **10.4 Drawing Technique – (Bridge Plans)**

1. Reinforcing Bar Requirements:
  - a. No duplicate bars are permitted within a structure element – abutment, pier, slab, etc. Duplicate bar is a bar that is the same size, length, and shape within the same structure element – Rear Abutment, Pier 1, Deck Slab. Duplicate bars are permitted in separate structure elements – Rear Abutment / Forward Abutment
  - b. Straight bars are to be rounded to nearest 3”, making sure requirements for bar clearance and bar laps are met.
  - c. Bent bars TOTAL lengths are to be rounded to the nearest inch.
2. Bridges are referenced by OTIC milepost number (MP 50.4) and road name (Wilkins Road) and not by ODOT designation of county-route-straight line mileage (not LUC-80-2.04).
3. Bridge plans are to be oriented so that north arrow is generally pointing up or to the right. The only exception to this is the plan view for the rear abutment, which in accordance with the ODOT BDM, is to be shown opposite the forward abutment.

## Appendix A: OTIC CAD Layer Names

UAF CAD LAYER STANDARD			
<i>STANDARD BRIDGE LAYER NAMES</i>			
LAYER NAME	LAYER DESCRIPTION	COLOR	LINETYPE
0	Default AutoCAD Layer - ** DO NOT DELETE **	white	white
BR_P_Approach_Slab	Proposed Bridge Approach Slab	magenta	Continuous
BR_P_Approach_Slab_Hidden	Proposed Bridge Approach Slab Hidden Line	green	HIDDEN2
BR_P_Beam_Centerline	Proposed Beam Centerline	yellow	CENTER2
BR_P_Beam_Hidden	Proposed Beam Hidden Line	green	HIDDEN2
BR_P_Beam_Object	Proposed Beam Object Line	magenta	Continuous
BR_P_Brg_Centerline	Proposed Bearing Centerline	yellow	CENTER2
BR_P_Brg_Det	Proposed Bearing Details	magenta	Continuous
BR_P_Const_Joint	Proposed Bridge Construction Joint	red	Continuous
BR_P_Det_Centerline	Proposed Other Centerline Details	yellow	CENTER2
BR_P_Det_Hidden	Proposed Other Hidden Details	green	HIDDEN2
BR_P_Det_Object	Proposed Other Object Detail	magenta	Continuous
BR_P_Drainage	Proposed Bridge Drainage	magenta	Continuous
BR_P_Ground_Slope	Proposed Bridge Ground Slope	magenta	Continuous
BR_P_Hatch	Proposed Bridge Hatching	cyan	Continuous
BR_P_Joint_Filler	Proposed Bridge Joint Filler	magenta	Continuous
BR_P_Porous_Backfill	Proposed Bridge Porous Backfill	magenta	Continuous
BR_P_Slab_Centerline	Proposed Deck Slab Centerline	yellow	CENTER2
BR_P_Slab_Const_Joint	Proposed Deck Slab Construction Joint	red	Continuous
BR_P_Slab_Hidden	Proposed Deck Slab Hidden Line	green	HIDDEN2
BR_P_Slab_Object	Proposed Deck Slab Object Line	magenta	Continuous
BR_P_Slab_Reinforcing	Proposed Deck Slab Reinforcing	red	Continuous
BR_P_Slope_Protection	Proposed Slope Protection	magenta	Continuous
BR_P_Sub_Centerline	Proposed Substructure Centerline	yellow	CENTER2
BR_P_Sub_Const_Joint	Proposed Substructure Construction Joint	red	Continuous
BR_P_Sub_Hidden	Proposed Substructure Hidden Line	green	HIDDEN2
BR_P_Sub_Object	Proposed Substructure Object Line	magenta	Continuous
BR_P_Sub_Reinforcing	Proposed Substructure Reinforcing Line	red	Continuous
BR_P_Text	Proposed General Bridge Text and Dimensions	red	Continuous
BR_P_Utility	Proposed Utilities	yellow	Continuous
BR_X_Approach_Slab	Existing Bridge Approach Slab	245	Continuous
BR_X_Approach_Slab_Hidden	Existing Bridge Approach Slab - Hidden	245	HIDDEN2
BR_X_Beam_Centerline	Existing Beam Centerline	245	CENTER2
BR_X_Beam_Hidden	Existing Beam Hidden Line	245	HIDDEN2
BR_X_Beam_Object	Existing Beam Object Line	245	Continuous
BR_X_Brg_Centerline	Existing Bearing Centerline	245	CENTER2

BR_X_Brg_Det	Existing Bearing Details	245	Continuous
BR_X_Const_Joint	Existing Construction Joint	245	Continuous
BR_X_Det_Centerline	Existing Other Centerline Details	245	CENTER2
BR_X_Det_Hidden	Existing Other Hidden Details	245	HIDDEN2
BR_X_Det_Object	Existing Other Object Details	245	Continuous
BR_X_Drainage	Existing Bridge Drainage	245	Continuous
BR_X_Ground_Slope	Existing Bridge Ground Slope	245	Continuous
BR_X_Hatch	Existing Bridge Hatching	245	Continuous
BR_X_Joint_Filler	Existing Bridge Joint Filler	245	Continuous
BR_X_Porous_Backfill	Existing Bridge Porous Backfill	245	Continuous
BR_X_Slab_Centerline	Existing Deck Slab Centerline	245	CENTER2
BR_X_Slab_Const_Joint	Existing Deck Slab Construction Joint	245	Continuous
BR_X_Slab_Hidden	Existing Deck Slab Hidden Line	245	HIDDEN2
BR_X_Slab_Object	Existing Deck Slab Object Line	245	Continuous
BR_X_Slab_Reinforcing	Existing Deck Slab Reinforcing	245	Continuous
BR_X_Slope_Protection	Existing Slope Protection	245	Continuous
BR_X_Sub_Centerline	Existing Substructure Centerline	245	CENTER2
BR_X_Sub_Const_Joint	Existing Substructure Construction Joint	245	Continuous
BR_X_Sub_Hidden	Existing Substructure Hidden Line	245	HIDDEN2
BR_X_Sub_Object	Existing Substructure Object Line	245	Continuous
BR_X_Sub_Reinforcing	Existing Substructure Reinforcing	245	Continuous
BR_X_Text	Existing General Bridge Text and Dimensions	red	Continuous
BR_X_Utility	Existing Utilities	245	Continuous
BR_X_Utility_Storm	Existing Storm Sewer	245	SDASH-70
BR_X_Utility_Wires_OH	Existing Overhead Utility Wires	247	2DASH-50
<b>STANDARD ROADWAY LAYER NAMES</b>			
RW_P_Const_Joint	Proposed Roadway Construction Joint	red	Continuous
RW_P_Det_Centerline	Proposed Other Centerline Details	yellow	CENTER2
RW_P_Det_Hidden	Proposed Other Hidden Details	green	HIDDEN2
RW_P_Det_Object	Proposed Other Object Detail	magenta	Continuous
RW_P_Drainage	Proposed Roadway Drainage	magenta	Continuous
RW_P_Edge_of_Pavement	Proposed Edge of Pavement Line	magenta	Continuous
RW_P_Edge_of_Shoulder	Proposed Edge of Shoulder Line	magenta	Continuous
RW_P_Ground_Slope	Proposed Roadway Ground Slope	magenta	Continuous
RW_P_Hatch	Proposed Roadway Hatching	cyan	Continuous
RW_P_Joint_Filler	Proposed Roadway Joint Filler	magenta	Continuous
RW_P_Porous_Backfill	Proposed Roadway Porous Backfill	magenta	Continuous
RW_P_Pavement_Centerline	Proposed Pavement Centerline	yellow	CENTER2
RW_P_Roadway_Centerline	Proposed Roadway Centerline	yellow	CENTER2
RW_P_Roadway_Object	Proposed Roadway Object Line	magenta	Continuous

RW_P_Roadway_Util_Object	Proposed Roadway Utility Object	magenta	Continuous
RW_P_Text	Proposed General RW Text and Dimensions	red	Continuous
RW_X_Const_Joint	Existing Roadway Construction Joint	245	Continuous
RW_X_Det_Centerline	Existing Other Centerline Details	245	CENTER2
RW_X_Det_Hidden	Existing Other Hidden Details	245	HIDDEN2
RW_X_Det_Object	Existing Other Object Detail	245	Continuous
RW_X_Drainage	Existing Roadway Drainage	245	Continuous
RW_X_Edge_of_Pavement	Existing Edge of Pavement Line	245	Continuous
RW_X_Edge_of_Shoulder	Existing Edge of Shoulder Line	245	Continuous
RW_X_Ground_Slope	Existing Roadway Ground Slope	245	Continuous
RW_X_Hatch	Existing Roadway Hatching	245	Continuous
RW_X_Joint_Filler	Existing Roadway Joint Filler	245	Continuous
RW_X_Porous_Backfill	Existing Roadway Porous Backfill	245	Continuous
RW_X_Pavement_Centerline	Existing Pavement Centerline	245	CENTER2
RW_X_Roadway_Centerline	Existing Roadway Centerline	245	CENTER2
RW_X_Roadway_Object	Existing Roadway Object Line	245	Continuous
RW_X_Roadway_Util_Object	Existing Roadway Utility Object	245	Continuous
RW_X_Text	Existing General RW Text and Dimensions	red	Continuous
<b>STANDARD GENERAL LAYER NAMES</b>			
Defpoints	Default	white	Continuous
SH_Border	Sheet Border	11	Continuous
SH_Checking_Print	Checking Print Stamp	white	Continuous
SH_Data	Sheet Data	white	Continuous
SH_Major_Grid_Line	Sheet Major Grid Line	249	Continuous
SH_Minor_Grid_Line	Sheet Minor Grid Line	244	Continuous
SH_Text	Sheet Text	red	Continuous
SH_Title_Block	Sheet Title Block	white	Continuous
SH_Viewport	Layout Viewports	30	Continuous

End of Appendix A- CAD Layer Standards

## Appendix B: OTIC CADD Drafting Conventions

Additional OTIC drawing techniques beyond ODOT’s Design manuals and drawing techniques described in the ODOT L&D (Location and Design) are described in Appendix B.

Object sizes shown are annotative scales.

### 1. Title Sheet Map Block: 3½”x 5½” Block

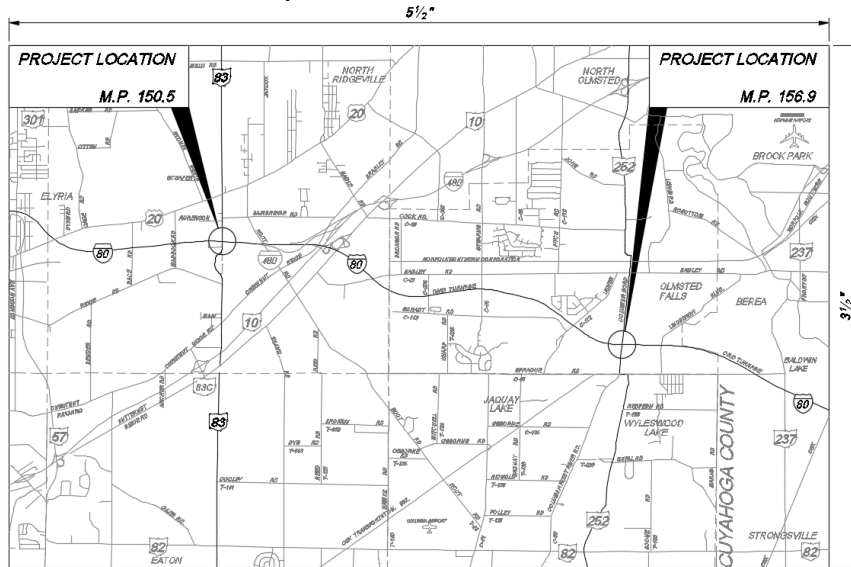

### 2. North Arrow Block: Annotative Object Scale 1½”

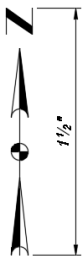

### 3. Lane Arrow Block: Annotative Object Scale 5/8”

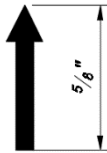

### 4. Section arrow Block: Annotative Object Scale 1/4”

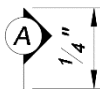

5. Typical welding symbol component sizes.

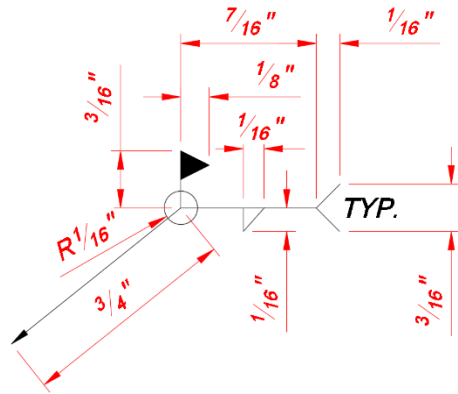

6. Hatch Patterns:

- a. ANSI37 – 1/2” Hatch Pattern scale (Structure Removed)



- b. ANSI31 – 1/4” Hatch Pattern scale (Structure Repaired)

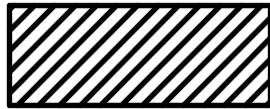

- c. Ground – 10.0 Hatch Pattern scale

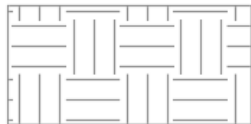

- d. Net – 12.0 Hatch Pattern scale, 45 Degree Angle (Proposed Fence)

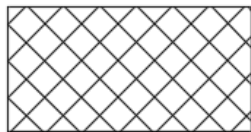

- e. Gravel – 3.0 Hatch Pattern scale, 45 (Backfill)

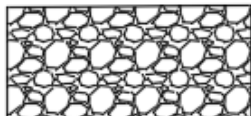

7. Dimensions: Dimension line spacing

a. Typical Horizontal line spacing distance

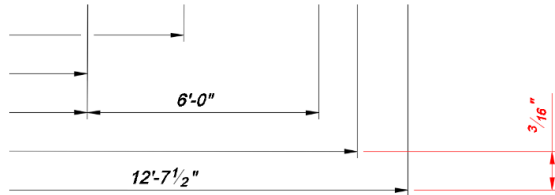

b. Typical Dimension spacing distance from an object

